



DELUXE MODEL B®

Wall / Ceiling Projection Screen

SPECIFICATION DATA

DA-LITE SCREEN COMPANY, INC.
 3100 North Detroit Street
 Post Office Box 137
 Warsaw, Indiana 46581-0137
 Phone: 574-267-8101
 800-622-3737
 Fax: 574-267-7804
 www.da-lite.com
 e-mail: info@da-lite.com

SUGGESTED SPECIFICATIONS: _____ projection screens, size _____ (H) x _____ (W), wall or ceiling mounting type. Surface to be Matte White, Glass Beaded, Video Spectra® 1.5, High Contrast Matte White, High Power or Silver Matte with black masking borders standard. Fabric shall be mounted into a metal strip in a metal Camlok roller system without tape, glue, staples or cords so that the fabric may be easily replaced yet cannot be pulled from roller. To have a painted white 22 gauge octagon steel case with flat back design and baked enamel finish and fitted with end caps concealing roller ends with integral bearing surface to support roller. End caps to have integral brackets for wall mounting by means of slotted screw holes and ceiling mounting by means of powder coated hanger rings. Bottom of fabric shall be mounted into a metal strip in a tubular steel slat finished in baked enamel. Ends of slat shall be protected by plastic outer caps. A metal saddle, with plated steel pull shall be attached to the slat. A permanently attached, self-concealing tension device shall have one end secured to the rear of the screen case and the other end extending through the slat pull, terminating in a contour-shaped, molded plastic rocker handle to lock and release the device. No cranks, levers or detachable devices shall be used. A 20" pull cord with plastic knob shall be attached to the saddle.

NOTE: Extension wall brackets required for wall mounting or mounting screen across a corner. See options below.

All surfaces will be seamless.

Silver Matte: Available in sizes up to 84" wide.

VIDEO FORMAT DIMENSIONS

Viewing Area		Nominal Diagonal Size		A - Overall Case Length		B - Distance Between Hangers		Brackets - Top to Case Bottom		Case Diameter (Width)		Approx. Ship. Wt.	
H x W	Cm	In.	Cm	In.	Cm	In.	Cm	In.	Cm	In.	Cm	Lbs.	Kg
43" x 57"	109 x 145	72"	183	63-3/8"	159	62-5/8"	159	3-1/2"	9	2-3/4"	7	18	8.2
50" x 67"	127 x 170	84"	213	73-3/8"	185	72-5/8"	185	3-1/2"	9	2-3/4"	7	23	10.4
60" x 80"	152 x 203	100"	254	87-3/8"	222	86-5/8"	220	3-1/2"	9	2-3/4"	7	28	12.7

HDTV FORMAT DIMENSIONS

Viewing Area		Nominal Diagonal Size		A - Overall Case Length		B - Distance Between Hangers		Brackets - Top to Case Bottom		Case Diameter (Width)		Approx. Ship. Wt.	
H x W	Cm	In.	Cm	In.	Cm	In.	Cm	In.	Cm	In.	Cm	Lbs.	Kg
45" x 80"	114 x 203	92"	234	87-3/8"	222	86-5/8"	220	3-1/2"	9	2-3/4"	7	28	12.7
52" x 92"	132 x 234	106"	269	99-3/8"	252	98-5/8"	251	3-1/2"	9	2-3/4"	7	31	14.1

DIMENSIONS

Sizes		A - Overall Case Length		B - Distance Between Hangers		Brackets - Top to Case Bottom		Case Diameter (Width)		Approx. Ship. Wt.	
H x W	Cm	In.	Cm	In.	Cm	In.	Cm	In.	Cm	Lbs.	Kg
50" x 50"	127 x 127	53-3/8"	135	52-5/8"	134	3-1/2"	9	2-3/4"	7	18	8.2
60" x 60"	152 x 152	63-3/8"	160	62-5/8"	159	3-1/2"	9	2-3/4"	7	21	9.5
70" x 70"	178 x 178	73-3/8"	185	72-5/8"	185	3-1/2"	9	2-3/4"	7	24	10.9

All screens standard with 2-1/2" black drop at top except 72" diagonal which has 4-1/2" and 84" and 100" diagonal, which have 6-1/2". Specifications subject to change without notice.

PLEASE MARK APPROPRIATE SELECTIONS:

Select viewing surface:

- Matte White
- Glass Beaded
- High Contrast Matte White
- Video Spectra® 1.5
- Silver Matte
- High Power

Optional Accessories:

- No. 6 Wall Bracket – extends 6" (15 Cm).
- No. 11 Wall Bracket – extends 10" (25 Cm) or 14" (36 Cm).
- No. 23 Adjustable Wall Bracket – extends 10" (25 Cm), 14" (36 Cm), 15-3/4" (40 Cm), 18-1/4" (46 Cm), 20" (51 Cm) or 24" (61 Cm).
- T-Bar Scissors Clip - for drop ceilings (black or white).
- Tilt Lock – keystone eliminator.
- No borders (Black masking borders standard).

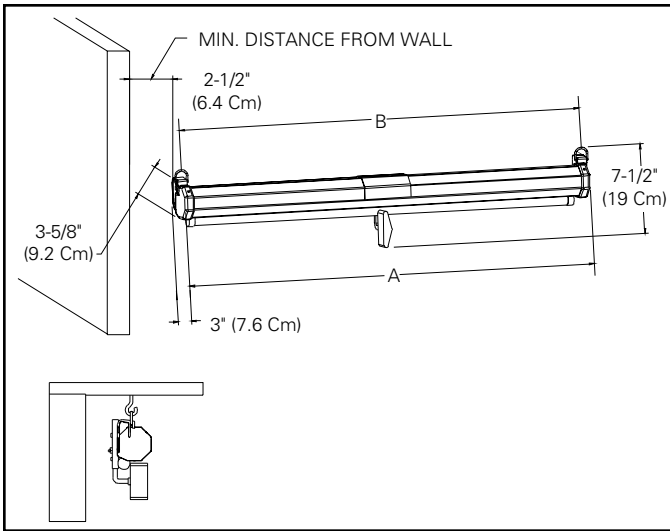

Project: _____

Architect: _____

Phone: _____

Contractor: _____

Phone: _____

Supervisor: _____

Phone: _____

Date: _____

Revised: _____

DELUXE MODEL B®

OPTIONAL ACCESSORIES

OPTIONAL ACCESSORIES: to provide chalkboard clearance: Furnish heavy extension wall brackets to mount screen 6" (15 Cm) from wall. To provide for keystone elimination: Furnish heavy extension wall brackets to mount screen 10" (25 Cm) or 14" (36 Cm) from wall or furnish heavy adjustable extension wall brackets to mount screen 10" (25 Cm), 14" (36 Cm), 15-3/4" (40 Cm), 18-1/4" (46 Cm), 20" (51 Cm) or 24" (61 Cm) from wall. Furnish magnetic tilt locks for keystone elimination.

NOTE: Brackets also are used for mounting screen across a corner.

EXTENSION WALL BRACKETS

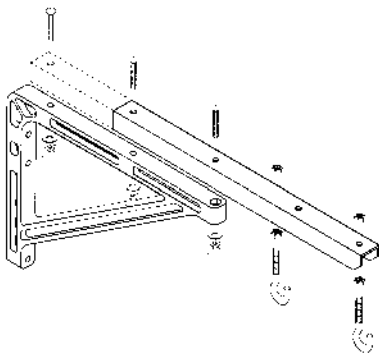

No. 23 ADJUSTABLE WALL BRACKET

Screen can be extended 18-1/4" (46 Cm), 20" (51 Cm) or 24" (61 Cm) from wall.

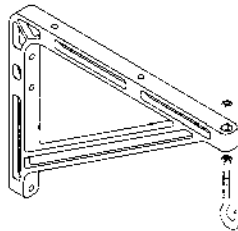

No. 11 WALL BRACKET

Screen can be extended 10" (25 Cm) or 14" (36 Cm) from wall by changing position of bracket.

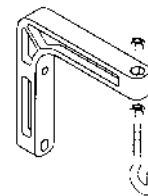

No. 6 WALL BRACKET

Screen can be extended 6" (15 Cm) from wall.

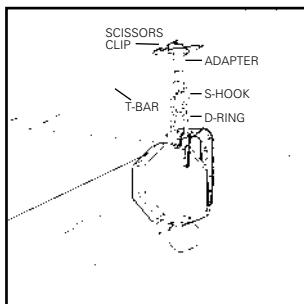

T-BAR SCISSORS CLIP for dropped ceiling, 50 lb. (22.68 Kg) capacity.

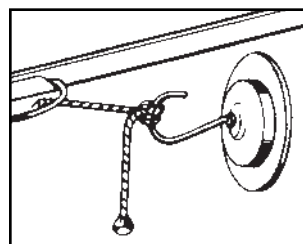

TILT LOCK for Keystone elimination. Used with extension brackets.